

SPHOORTI

Precision Assured

BT TOOL HOLDERS
JIS B 6339 (MAS 403)
FOR CNC MACHINING CENTER



January 2017

SHANK TYPE BT

FORM A

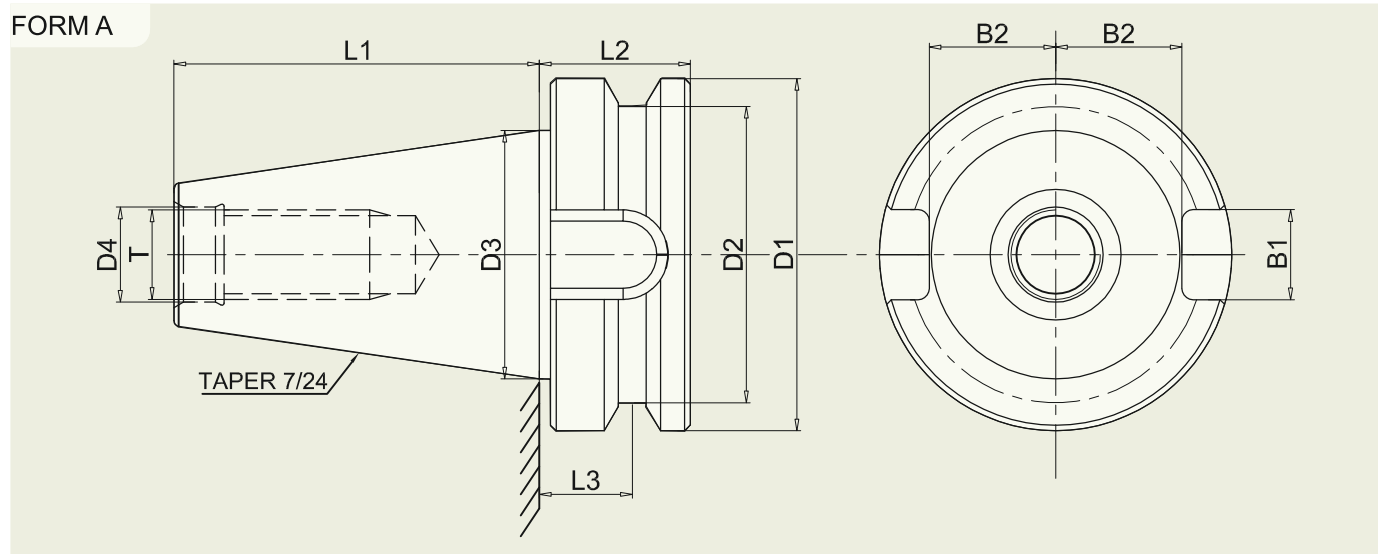

TAPER	D1	D2	D3	D4	L1	L2	L3	T	B1	B2
30	46	38	31.75	12.5	48.4	22	13.6	M12	16.1	16.3
40	63	53	44.45	17	65.4	27	16.6	M16	16.1	22.6
50	100	85	69.85	25	101.8	38	23.2	M24	25.7	35.4

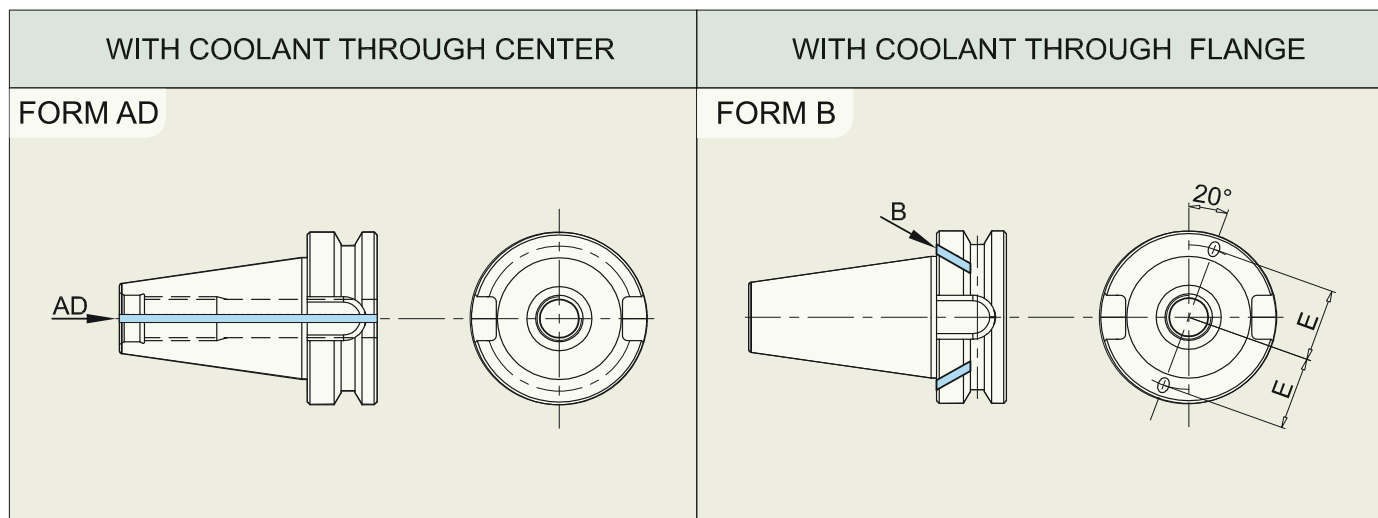

FEATURES:

- Tool holder are made out of case-hardened Steel.
- Tool holder are case-hardened 58±2 HRC.
- Tensile strength in the core at least 800 N/mm².
- Taper Shank Angular Tolerance Better Than AT3 Class.

COLLET CHUCKS FOR COLLETS DIN 6499

FORM A (WITHOUT COOLANT)

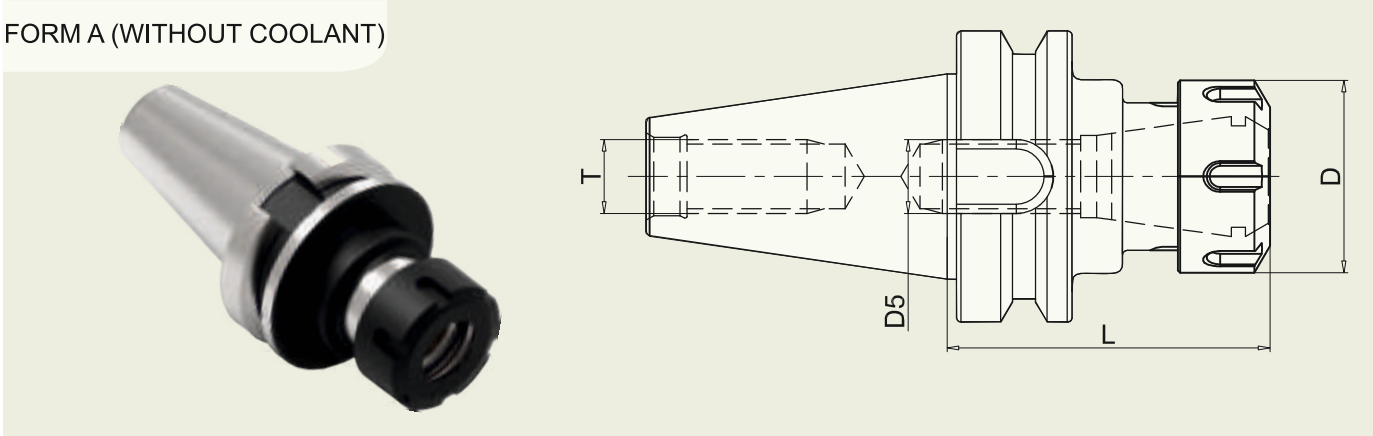

ADAPTER CODE	SUITS FOR COLLET	CLAMPING RANGE	L	T	D5	NUT (DIA) D	NUT CODE	SPANNER CODE
BT40-ER16-070A	ER 16	0.5-10	70	M16	M10	28	ER16-DIN6499	SW 25
BT40-ER16-100A	ER 16	0.5-10	100	M16	M10	28	ER16-DIN6499	SW 25
BT40-ER16-160A	ER 16	0.5-10	160	M16	M10	28	ER16-DIN6499	SW 25
BT40-ER20-070A	ER 20	1-13	70	M16	M12	34	ER20-DIN6499	S 20
BT40-ER20-100A	ER 20	1-13	100	M16	M12	34	ER20-DIN6499	S 20
BT40-ER20-160A	ER 20	1-13	160	M16	M12	34	ER20-DIN6499	S 20
BT40-ER25-070A	ER 25	1-16	70	M16	M16	42	ER25-DIN6499	S 25
BT40-ER25-100A	ER 25	1-16	100	M16	M16	42	ER25-DIN6499	S 25
BT40-ER25-160A	ER 25	1-16	160	M16	M16	42	ER25-DIN6499	S 25
BT40-ER32-070A	ER 32	2-20	70	M16	M16	50	ER32-DIN6499	S 32
BT40-ER32-100A	ER 32	2-20	100	M16	M16	50	ER32-DIN6499	S 32
BT40-ER32-160A	ER 32	2-20	160	M16	M16	50	ER32-DIN6499	S 32
BT40-ER40-070A	ER 40	3-26	70	M16	M16	63	ER40-DIN6499	S 40
BT40-ER40-100A	ER 40	3-26	100	M16	M16	63	ER40-DIN6499	S 40
BT40-ER40-160A	ER 40	3-26	160	M16	M16	63	ER40-DIN6499	S 40

ORDERING EXAMPLE:

BT40-ER16-070 A

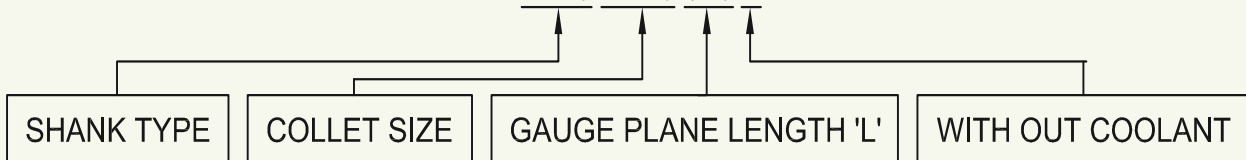

COLLET CHUCKS FOR COLLETS DIN 6499

FORM AD (COOLANT THROUGH CENTER)

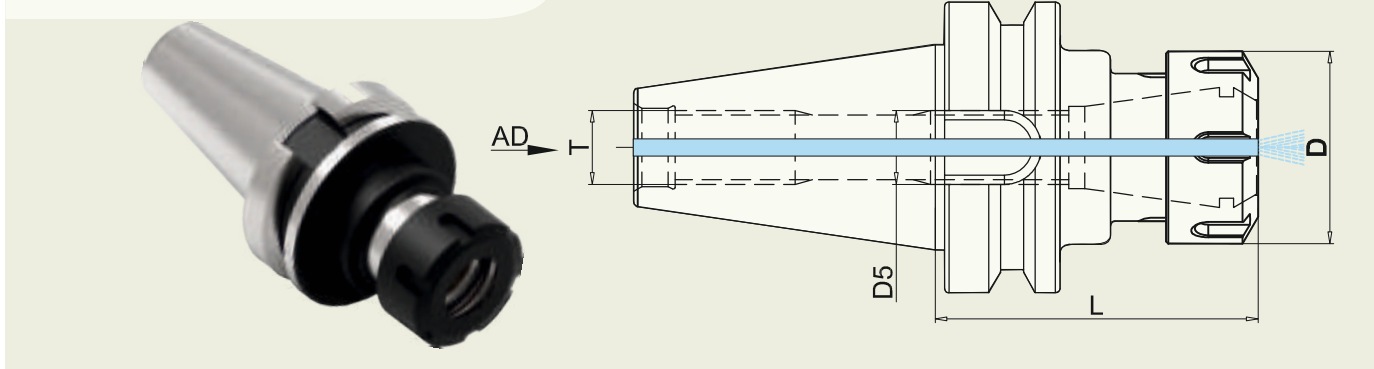

ADAPTER CODE	SUITS FOR COLLET	CLAMPING RANGE	L	T	D5	NUT (DIA) D	NUT CODE	SPANNER CODE
BT40-ER16-070AD	ER 16	0.5-10	70	M16	M10	28	ER16-DIN6499	SW 25
BT40-ER16-100AD	ER 16	0.5-10	100	M16	M10	28	ER16-DIN6499	SW 25
BT40-ER16-160AD	ER 16	0.5-10	160	M16	M10	28	ER16-DIN6499	SW 25
BT40-ER20-070AD	ER 20	1-13	70	M16	M12	34	ER20-DIN6499	S 20
BT40-ER20-100AD	ER 20	1-13	100	M16	M12	34	ER20-DIN6499	S 20
BT40-ER20-160AD	ER 20	1-13	160	M16	M12	34	ER20-DIN6499	S 20
BT40-ER25-070AD	ER 25	1-16	70	M16	M16	42	ER25-DIN6499	S 25
BT40-ER25-100AD	ER 25	1-16	100	M16	M16	42	ER25-DIN6499	S 25
BT40-ER25-160AD	ER 25	1-16	160	M16	M16	42	ER25-DIN6499	S 25
BT40-ER32-070AD	ER 32	2-20	70	M16	M16	50	ER32-DIN6499	S 32
BT40-ER32-100AD	ER 32	2-20	100	M16	M16	50	ER32-DIN6499	S 32
BT40-ER32-160AD	ER 32	2-20	160	M16	M16	50	ER32-DIN6499	S 32
BT40-ER40-070AD	ER 40	3-26	70	M16	M16	63	ER40-DIN6499	S 40
BT40-ER40-100AD	ER 40	3-26	100	M16	M16	63	ER40-DIN6499	S 40
BT40-ER40-160AD	ER 40	3-26	160	M16	M16	63	ER40-DIN6499	S 40

ORDERING EXAMPLE:

BT40-ER16-070 AD

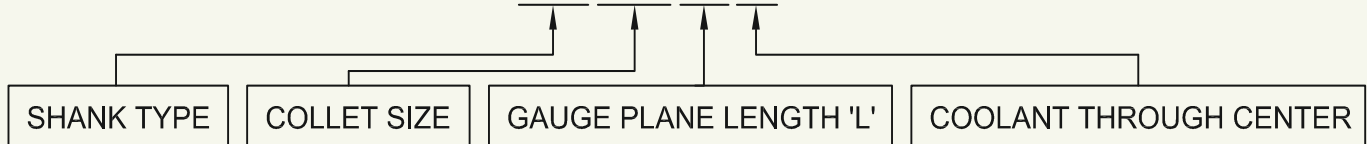

TOOL HOLDER JIS B 6339 (MAS 403)

COLLET CHUCKS FOR COLLETS DIN 6499

FORM ADB (COOLANT THROUGH CENTER & FLANGE)

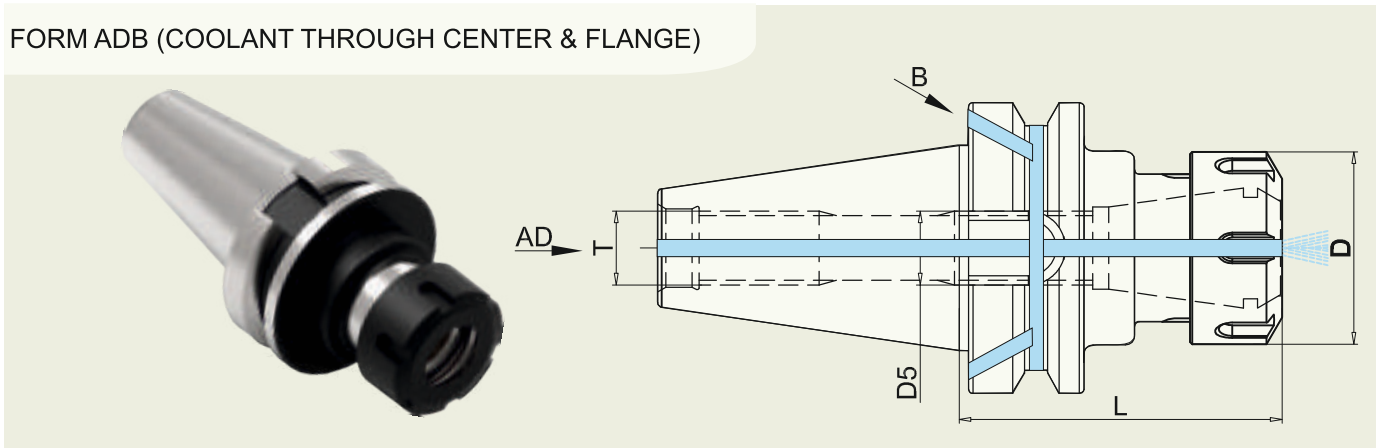

ADAPTER CODE	SUITS FOR COLLET	CLAMPING RANGE	L	T	D5	NUT (DIA) D	NUT CODE	SPANNER CODE
BT40-ER16-070ADB	ER 16	0.5-10	70	M16	M10	28	ER16-DIN6499	SW 25
BT40-ER16-100ADB	ER 16	0.5-10	100	M16	M10	28	ER16-DIN6499	SW 25
BT40-ER16-160ADB	ER 16	0.5-10	160	M16	M10	28	ER16-DIN6499	SW 25
BT40-ER20-070ADB	ER 20	1-13	70	M16	M12	34	ER20-DIN6499	S 20
BT40-ER20-100ADB	ER 20	1-13	100	M16	M12	34	ER20-DIN6499	S 20
BT40-ER20-160ADB	ER 20	1-13	160	M16	M12	34	ER20-DIN6499	S 20
BT40-ER25-070ADB	ER 25	1-16	70	M16	M16	42	ER25-DIN6499	S 25
BT40-ER25-100ADB	ER 25	1-16	100	M16	M16	42	ER25-DIN6499	S 25
BT40-ER25-160ADB	ER 25	1-16	160	M16	M16	42	ER25-DIN6499	S 25
BT40-ER32-070ADB	ER 32	2-20	70	M16	M16	50	ER32-DIN6499	S 32
BT40-ER32-100ADB	ER 32	2-20	100	M16	M16	50	ER32-DIN6499	S 32
BT40-ER32-160ADB	ER 32	2-20	160	M16	M16	50	ER32-DIN6499	S 32
BT40-ER40-070ADB	ER 40	3-26	70	M16	M16	63	ER40-DIN6499	S 40
BT40-ER40-100ADB	ER 40	3-26	100	M16	M16	63	ER40-DIN6499	S 40
BT40-ER40-160ADB	ER 40	3-26	160	M16	M16	63	ER40-DIN6499	S 40

ORDERING EXAMPLE:

BT40-ER16-070 ADB

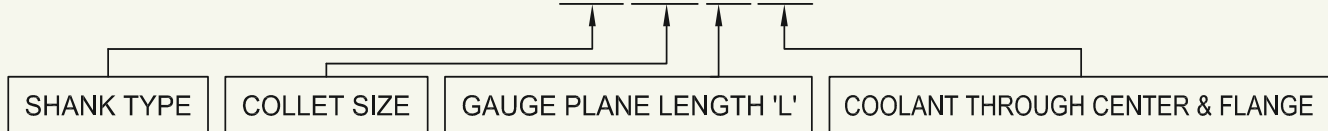

SIDE LOCK HOLDERS

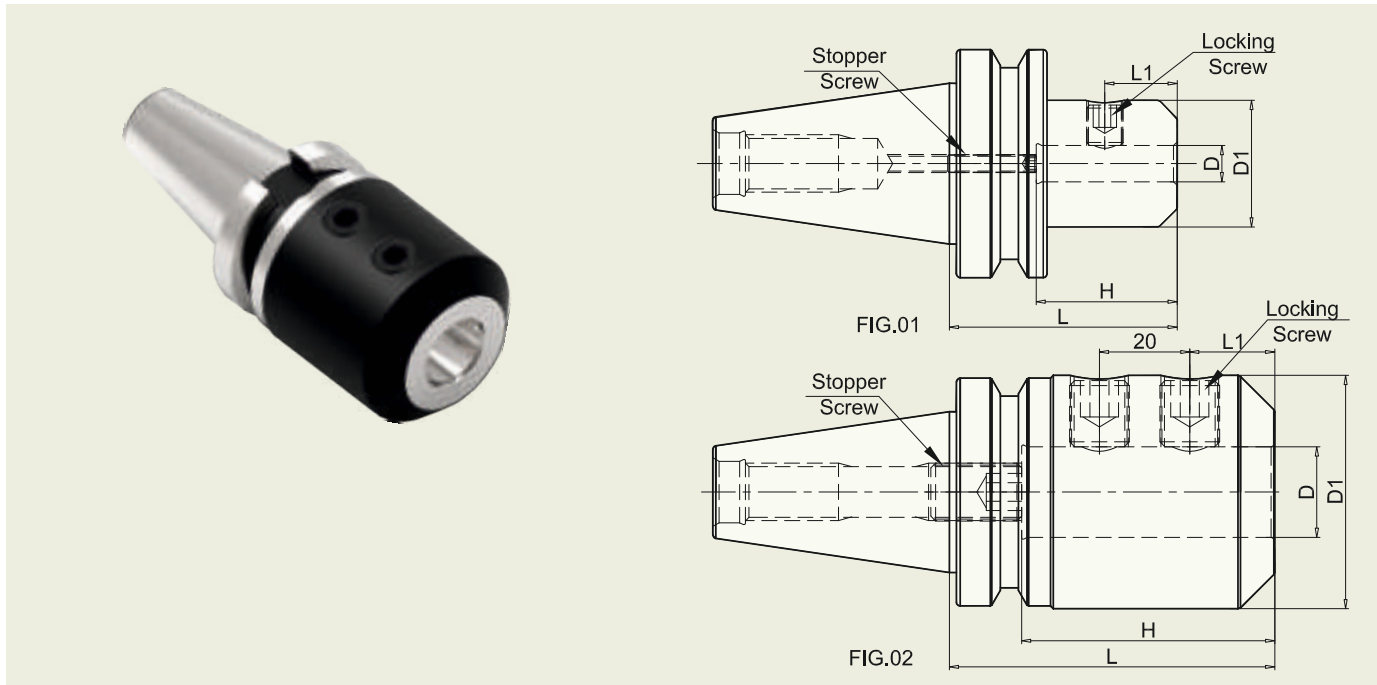

ADAPTER CODE	D	L	D1	L1	H	LOCKING SCREW	STOPPER SCREW	FIG
BT40-SLA06-050	6	50	25	18	35	M6	M5X20	1
BT40-SLA08-050	8	50	28	18	35	M8	M6X20	1
BT40-SLA10-063	10	63	35	20	39	M10	M8X25	1
BT40-SLA12-063	12	63	42	23	44	M12	M10X30	1
BT40-SLA16-063	16	63	48	24	47	M12	M12X30	1
BT40-SLA20-090	20	90	50	25	70	M10	M16X30	2
BT40-SLA25-090	25	90	50	25	70	M10	M16X30	2
BT40-SLA32-090	32	90	60	30	70	M10	M16X30	2
BT40-SLA40-090	40	90	60	30	70	M10	M16X30	2

ORDERING EXAMPLE:

BT40-SLA06-050

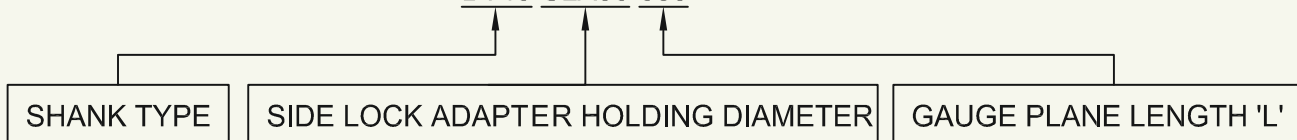

FACE MILL HOLDERS

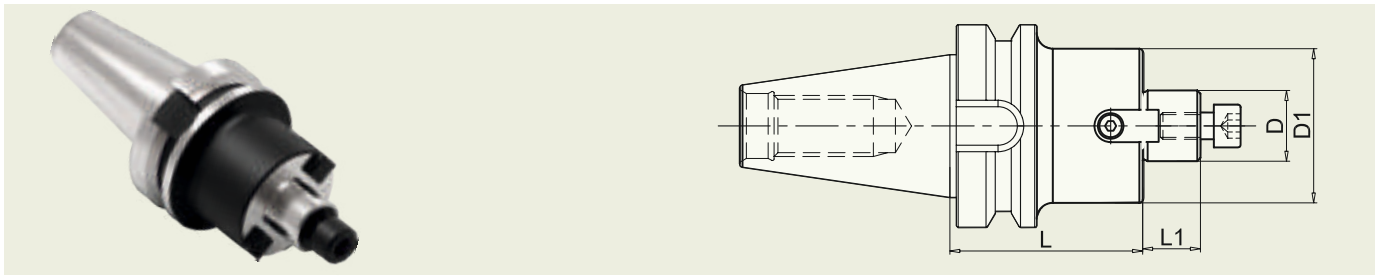

ADAPTER CODE	D	D1	L	L1
BT40-FMH22-045	22	48	45	19
BT40-FMH22-060	22	48	60	19
BT40-FMH22-090	22	48	90	19
BT40-FMH27-045	27	58	45	21
BT40-FMH27-060	27	58	60	21
BT40-FMH27-090	27	58	90	21
BT40-FMH32-045	32	78	45	24
BT40-FMH32-060	32	78	60	24
BT40-FMH32-090	32	78	90	24

ORDERING EXAMPLE:
BT40-FMH 22-045

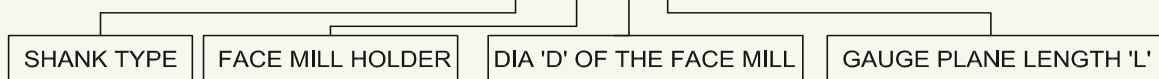

BORING BAR BLANKS

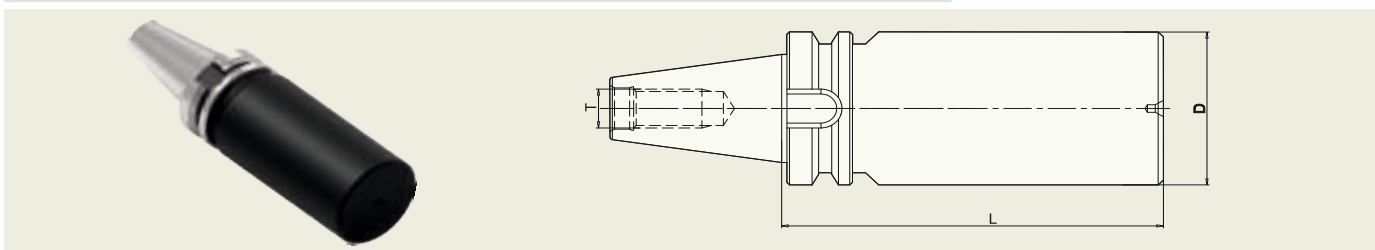

ADAPTER CODE	D	L	T
BT40-BBB-63-150	63	150	M16
BT40-BBB-63-200	63	200	M16

ORDERING EXAMPLE:
BT40-BBB-63-150



TOOL HOLDER JIS B 6339 (MAS 403)

SPHOORTI
Precision Assured

MORSE TAPER ADAPTERS

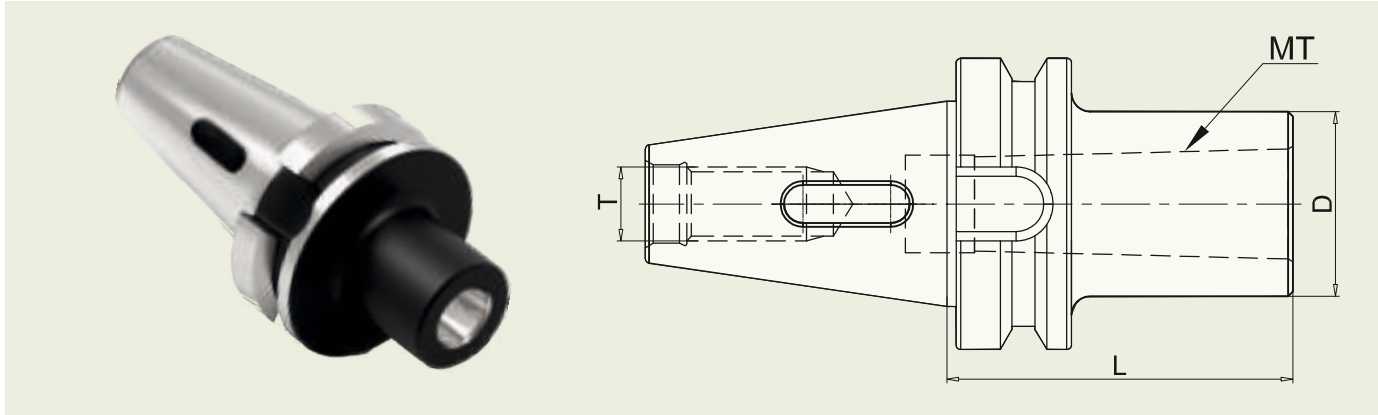

ADAPTER CODE	MORSE TAPER (MT)	L	T	D
BT40-MT1-045	1	45	M16	25
BT40-MT1-115	1	115	M16	25
BT40-MT2-060	2	60	M16	32
BT40-MT2-125	2	125	M16	32
BT40-MT3-075	3	75	M16	40
BT40-MT3-140	3	140	M16	40
BT40-MT4-095	4	95	M16	48

ORDERING EXAMPLE:

BT40-MT1-045

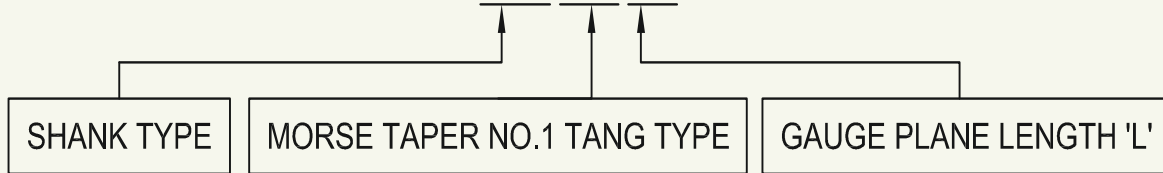

SPHOORTI

Precision Assured

Sphoorti Machine Tools Pvt. Ltd.
18, Plot No. 467 - 469, 12th Cross, IV Phase
Peenya Industrial Area, Bangalore - 560 058. INDIA.
Ph. : +91 80 4127 2768, Fax : +91 80 4117 1589
E-mail : info@sphoorti.com
URL : <http://www.sphoorti.com>