

SPHOORTI

Precision Assured



DRIVEN TOOL HOLDERS

FOR CNC TURN MILL CENTERS
AS PER DIN 5482, 5480, 1809 & TOEM.

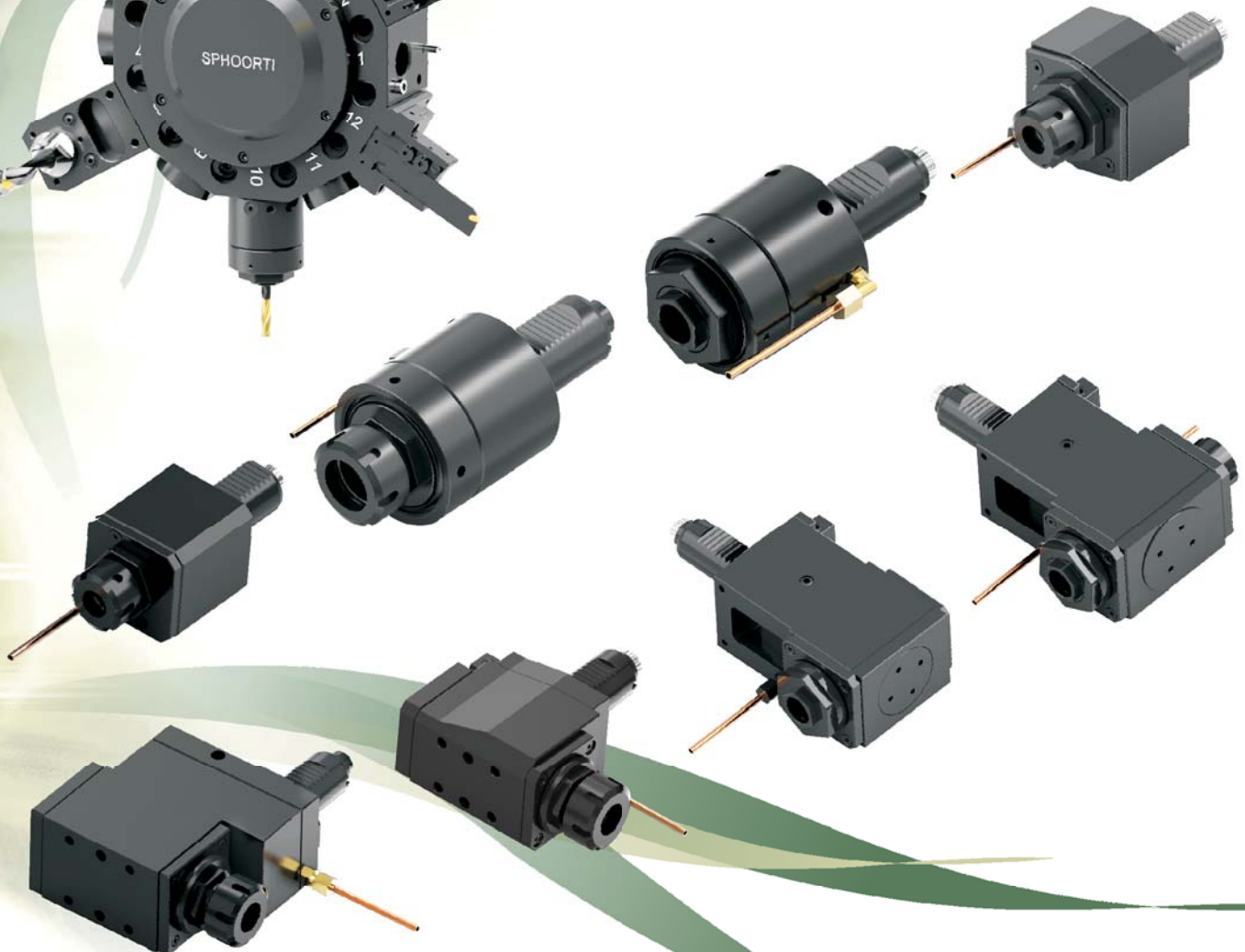

AXIAL TOOL HEAD - SQUARE

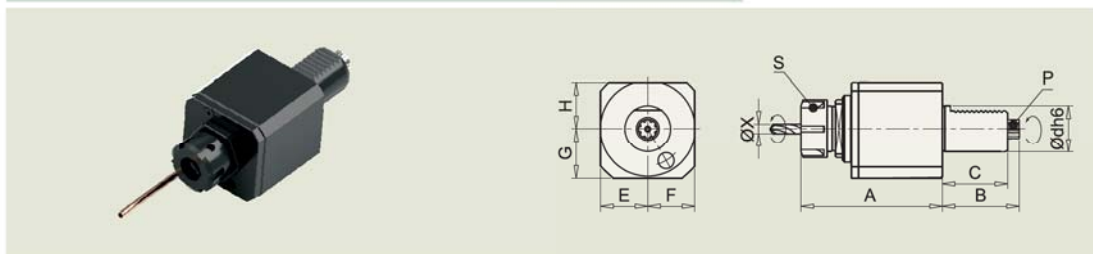

CODE	Ødh6	A	B	C	E	F	G	H	ØX	i	N _{max} RPM	S (DIN 6499)	T Nm	P	SUITS FOR
SD6102	30	94	55	45	30	30	30	28	1-13	1:1	6000	ER20	40	B15X12-9b	DRIVEN TOOL DISC VDI Ø30 BORE
SD6112	30	98.5	55	45	30	30	30	28	1-16	1:1	6000	ER25	40	B15X12-9b	DRIVEN TOOL DISC VDI Ø30 BORE
SD6202	40	123	63	53	41	41	43	40	1-20	1:1	5000	ER32	70	B17X14-9b	DRIVEN TOOL DISC VDI Ø40 BORE

AXIAL TOOL HEAD - ROUND - EXT NUT

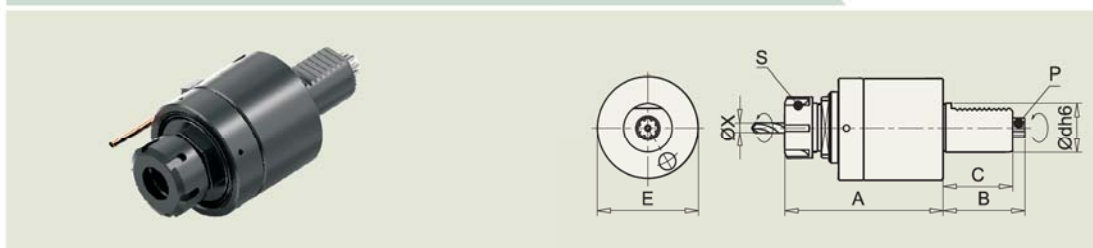

CODE	Ødh6	A	B	C	E	ØX	i	N _{max} RPM	S (DIN 6499)	T Nm	P	SUITS FOR
SD6113	30	98.5	55	45	68	1-16	1:1	6000	ER25	40	B15X12-9b	DRIVEN TOOL DISC VDI Ø30 BORE
SD6211	40	120.5	63	53	83	1-20	1:1	5000	ER32	70	B17X14-9b	DRIVEN TOOL DISC VDI Ø40 BORE

AXIAL TOOL HEAD - ROUND - INT NUT

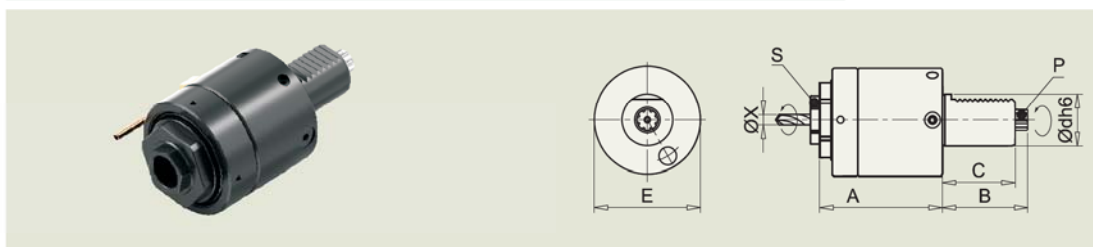

CODE	Ødh6	A	B	C	E	ØX	i	N _{max} RPM	S (DIN 6499)	T Nm	P	SUITS FOR
SD6116	30	80	55	45	68	1-16	1:1	6000	ER25	40	B15X12-9b	DRIVEN TOOL DISC VDI Ø30 BORE
SD6225	40	95	63	53	83	1-20	1:1	5000	ER32	70	B17X14-9b	DRIVEN TOOL DISC VDI Ø40 BORE

AXIAL TOOL HEAD - SHORT

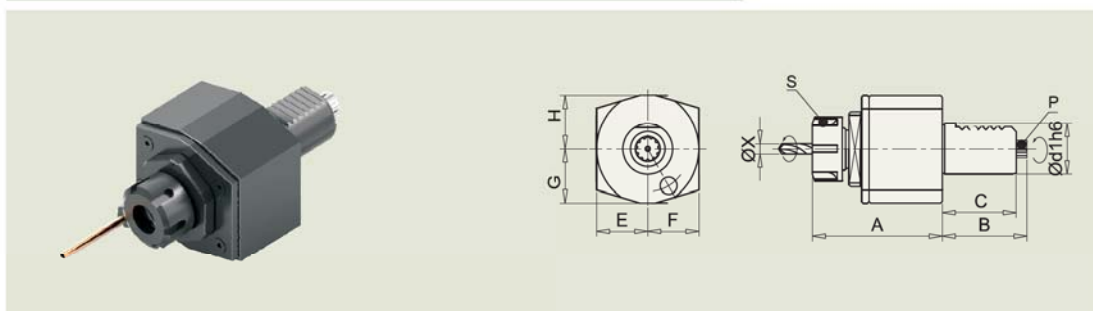

CODE	Ødh6	A	B	C	E	F	G	H	ØX	i	N _{max} RPM	S (DIN 6499)	T Nm	P	SUITS FOR
SD6104	30	78	55	45	35	35	33	33	1-13	1:1	4000	ER20	40	B15X12-9b	DRIVEN TOOL DISC VDI Ø30 BORE
SD6204	40	85	63	53	42.5	42.5	38	38	1-20	1:1	4000	ER32	70	B17X14-9b	DRIVEN TOOL DISC VDI Ø40 BORE

RADIAL TOOL HEAD

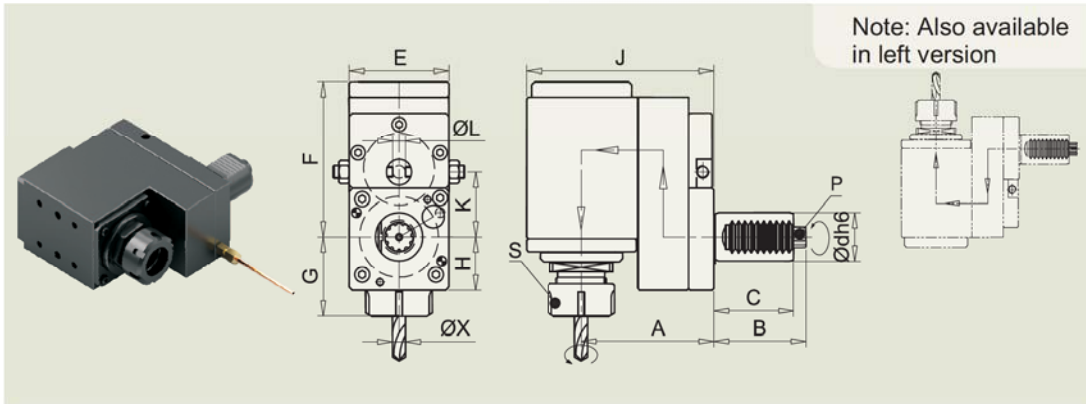

CODE	Ødh6	A	B	C	E	F	G	H	J	K	ØL	ØX	i	N _{max} RPM	S (DIN 6499)	T Nm	VERSION	P	SUITS FOR
SD6110	30	89	55	45	63	96.5	49	33	124	40	8	1-16	1:1	6000	ER25	40	R	B15X12-9b	DRIVEN TOOL DISC VDI Ø30 BORE
SD6210	40	98	63	53	80	108.5	43	43	138	63	10	1-20	1:1	5000	ER32	70	R	B17X14-9b	DRIVEN TOOL DISC VDI Ø40 BORE

RADIAL TOOL HEAD - DIRECT

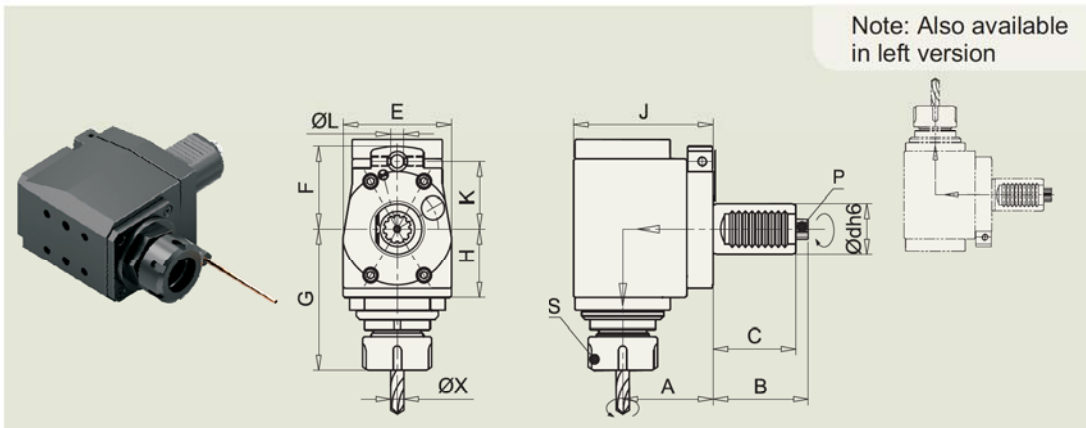

CODE	Ødh6	A	B	C	E	F	G	H	J	K	ØL	ØX	i	N _{max} RPM	S (DIN 6499)	T Nm	VERSION	P	SUITS FOR
SD6115	30	55	55	45	66	53	84.5	41.5	85	40	8	1-16	1:1	6000	ER25	40	R	B15X12-9b	DRIVEN TOOL DISC VDI Ø30 BORE
SD6215	40	64	63	53	76	74	90	43	98	63	10	1-20	1:1	5000	ER32	70	R	B17X14-9b	DRIVEN TOOL DISC VDI Ø40 BORE

RADIAL TOOL HEAD - INT NUT - THROUGH COOLANT

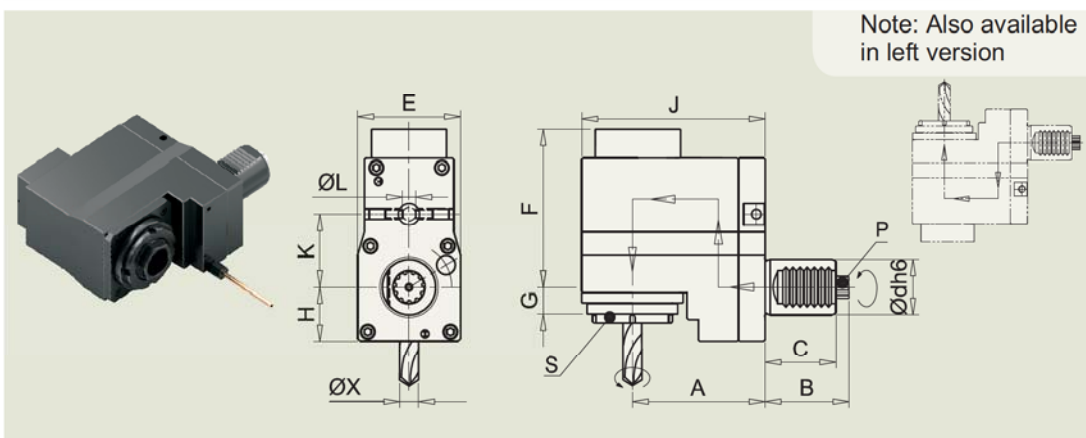

CODE	Ødh6	A	B	C	E	F	G	H	J	K	ØL	ØX	i	N _{max} RPM	S (DIN 6499)	T Nm	VERSION	P	SUITS FOR
SD6213	40	99.5	63	53	77	115.5	33	39.5	137.5	63	10	1-20	1:1	5000	ER32	70	R	B17X14-9b	DRIVEN TOOL DISC VDI Ø40 BORE

AXIAL TOOL HEAD - SQUARE - EXT NUT

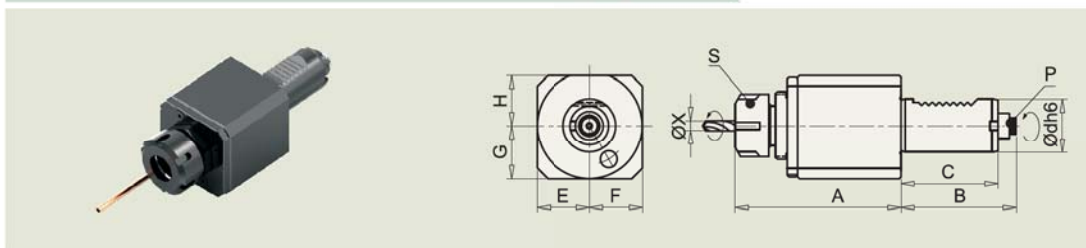

CODE	Ødh6	A	B	C	E	F	G	H	ØX	i	N _{max} RPM	S (DIN 6499)	T Nm	P	SUITS FOR
SD5901	16	65	42	32	21	25	21	21	1-7	1:1	6000	ER11	6.3	W8X0.8X30°X8-9b	DRIVEN TOOL DISC VDI Ø16 BORE
SD6002	20	94	51	40	30	30	27	28	1-13	1:1	6000	ER20	10	W10X0.8X30°X11-9b	DRIVEN TOOL DISC VDI Ø20 BORE
SD6106	30	94	67	55	30	30	30	28	1-13	1:1	6000	ER20	40	W16X0.8X30°X18-9b	DRIVEN TOOL DISC VDI Ø30 BORE
SD6111	30	98.5	67	55	30	30	30	28	1-16	1:1	6000	ER25	40	W16X0.8X30°X18-9b	DRIVEN TOOL DISC VDI Ø30 BORE
SD6207	40	123	75	63	41	41	43	40	1-20	1:1	5000	ER32	70	W20X0.8X30°X24-9b	DRIVEN TOOL DISC VDI Ø40 BORE

AXIAL TOOL HEAD - ROUND - EXT NUT

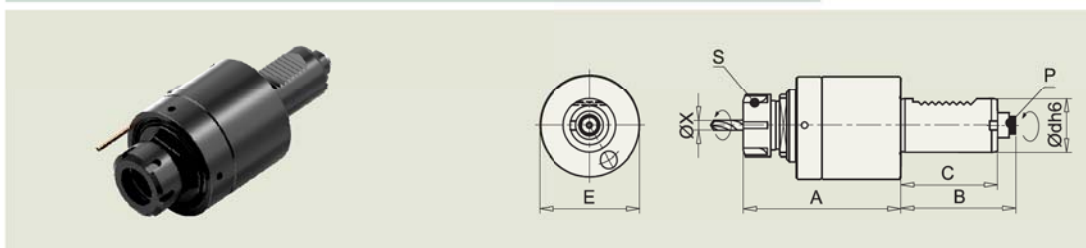

CODE	Ødh6	A	B	C	E	ØX	i	N _{max} RPM	S (DIN 6499)	T Nm	P	SUITS FOR
SD6122	30	99.5	67	55	68	1-16	1:1	6000	ER25	40	W16X0.8X30°X18-9b	DRIVEN TOOL DISC VDI Ø30 BORE
SD6224	40	120.5	75	63	83	1-20	1:1	5000	ER32	70	W20X0.8X30°X24-9b	DRIVEN TOOL DISC VDI Ø40 BORE

AXIAL TOOL HEAD - ROUND - INT NUT

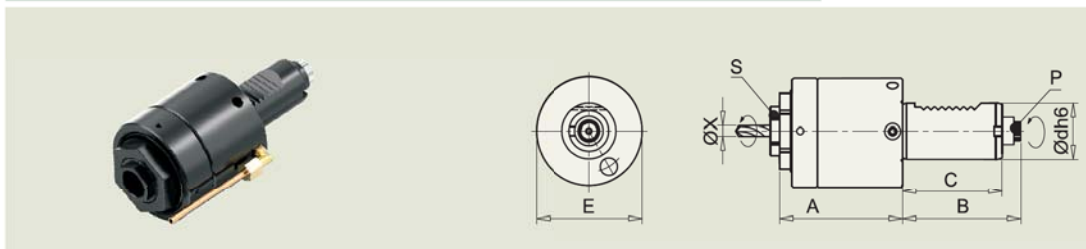

CODE	Ødh6	A	B	C	E	ØX	i	N _{max} RPM	S (DIN 6499)	T Nm	P	SUITS FOR
SD6117	30	80	67	55	68	1-16	1:1	6000	ER25	40	W16X0.8X30°X18-9b	DRIVEN TOOL DISC VDI Ø30 BORE
SD6226	40	95	75	63	83	1-20	1:1	5000	ER32	70	W20X0.8X30°X24-9b	DRIVEN TOOL DISC VDI Ø40 BORE

AXIAL TOOL HEAD - SHORT

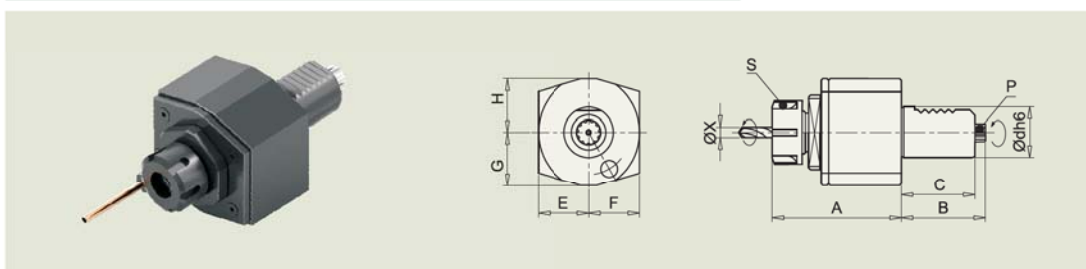

CODE	Ødh6	A	B	C	E	F	G	H	ØX	i	S (DIN 6499)	N _{max} RPM	T Nm	P	SUITS FOR
SD6004	20	76	51	40	31	31	35	28	1-10	1:1	4000	ER16	10	W10X0.8X30°X11-9b	DRIVEN TOOL DISC VDI Ø20 BORE

AXIAL TOOL HEAD - INT NUT-THROUGH COOLANT

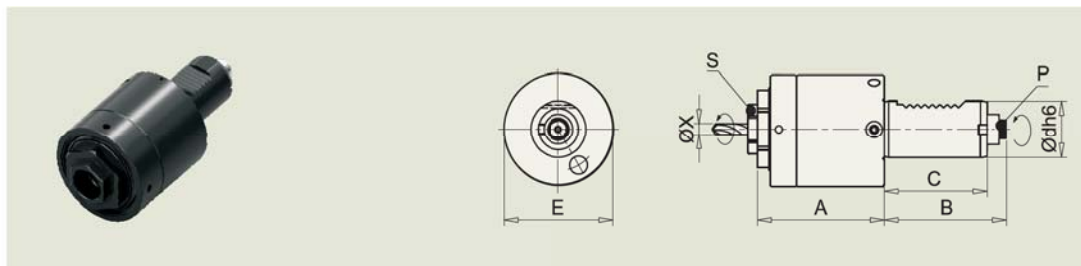

CODE	Ødh6	A	B	C	E	ØX	i	N _{max} RPM	S (DIN 6499)	T Nm	P	SUITS FOR
SD6136	30	80	67	55	68	1-16	1:1	6000	ER25	40	W16X0.8X30°X18-9b	DRIVEN TOOL DISC VDI Ø30 BORE
SD6232	40	95	75	63	83	1-20	1:1	5000	ER32	70	W20X0.8X30°X24-9b	DRIVEN TOOL DISC VDI Ø40 BORE

RADIAL TOOL HEAD

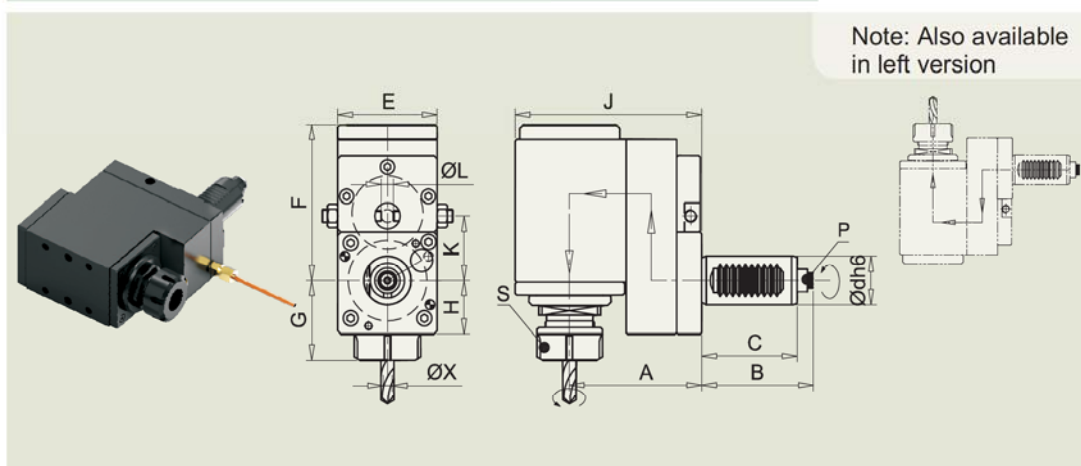

CODE	Ødh6	A	B	C	E	F	G	H	J	K	ØL	ØX	i	N _{max} RPM	S (DIN 6499)	T Nm	VERSION	P	SUITS FOR
SD6007	20	57	51	40	50	70	49	33	119	40	8	1-16	1:1	6000	ER25	10	R	W10X0.8X30°X11-9b	DRIVEN TOOL DISC VDI Ø20 BORE
SD6132	30	89	67	55	63	96.5	49	33	124	48	8	1-16	1:1	6000	ER25	40	R	W16X0.8X30°X18-9b	DRIVEN TOOL DISC VDI Ø30 BORE
SD6231	40	98	75	63	80	108.5	43	43	138	56	10	1-20	1:1	5000	ER32	70	R	W20X0.8X30°X24-9b	DRIVEN TOOL DISC VDI Ø40 BORE

RADIAL TOOL HEAD - DIRECT

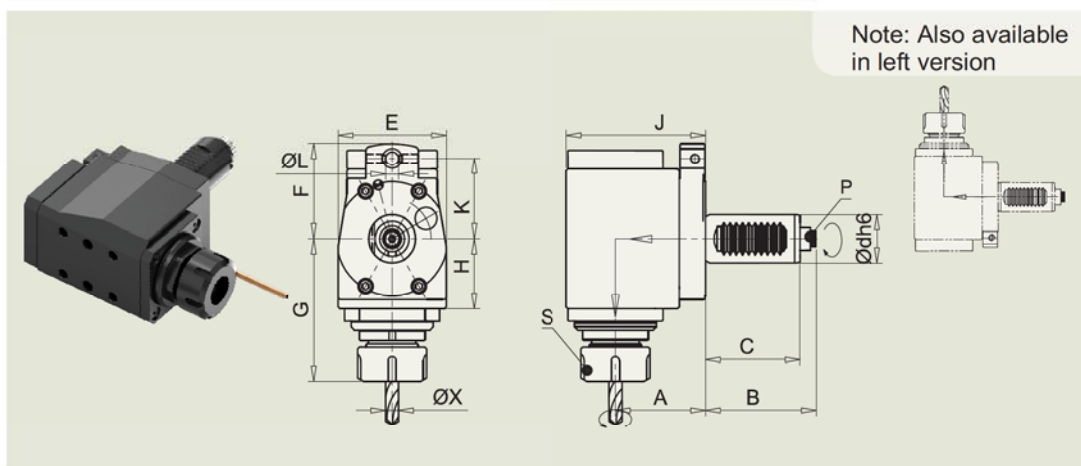

CODE	Ødh6	A	B	C	E	F	G	H	J	K	ØL	ØX	i	S (DIN 6499)	N _{max} RPM	T Nm	VERSION	P	SUITS FOR
SD5902	16	34	42	32	42	61	46	25	50	54	8	1-7	1:1	6000	ER11	6.3	R	W8X0.8X30°X8-9b	DRIVEN TOOL DISC VDI Ø16 BORE
SD6130	30	55	67	55	66	53	84.5	41.5	85	48	8	1-16	1:1	6000	ER25	40	R	W16X0.8X30°X18-9b	DRIVEN TOOL DISC VDI Ø30 BORE
SD6221	40	64	75	63	76	69	90	43	98	56	10	1-20	1:1	5000	ER32	70	R	W20X0.8X30°X24-9b	DRIVEN TOOL DISC VDI Ø40 BORE

AXIAL TOOL HEAD - FOR RADIAL DISC

SINGLE END

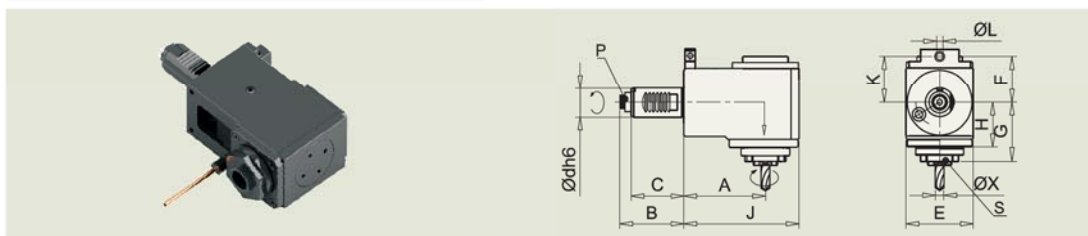

CODE	Ødh6	A	B	C	E	F	G	H	J	K	ØL	ØX	i	N _{max} RPM	S (DIN 6499)	T Nm	VERSION	P	SUITS FOR
SD6114	30	85	67	55	70	49.5	64.5	45.5	120	48	8	1-16	1:1	6000	ER25	40	R	W16X0.8X30°X18-9b	DRIVEN TOOL DISC VDI Ø30 BORE
SD6214	40	100	75	63	76	54	74.5	53	144	56	10	1-20	1:1	5000	ER32	70	R	W20X0.8X30°X24-9b	DRIVEN TOOL DISC VDI Ø40 BORE

SINGLE END - THROUGH COOLANT

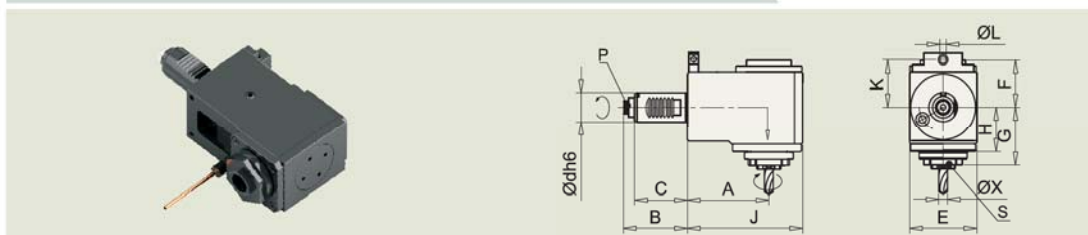

CODE	Ødh6	A	B	C	E	F	G	H	J	K	ØL	ØX	i	N _{max} RPM	S (DIN 6499)	T Nm	VERSION	P	SUITS FOR
SD6135	30	85	67	55	70	58.5	64.5	45.5	120	48	8	1-16	1:1	6000	ER25	40	R	W16X0.8X30°X18-9b	DRIVEN TOOL DISC VDI Ø30 BORE
SD6230	40	100	75	63	76	64.5	74.5	53	144	56	10	1-20	1:1	5000	ER32	70	R	W20X0.8X30°X24-9b	DRIVEN TOOL DISC VDI Ø40 BORE

SINGLE END - DOUBLE SERRATION

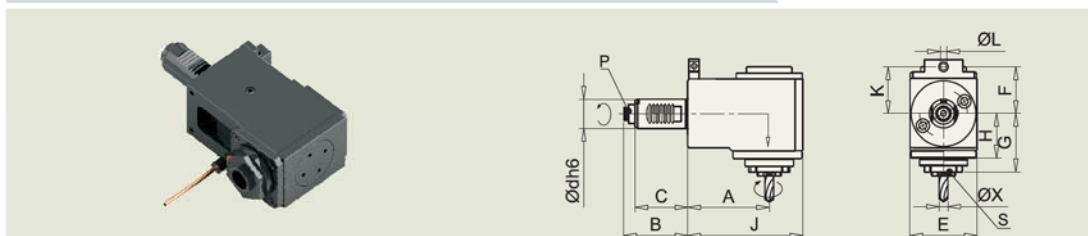

CODE	Ødh6	A	B	C	E	F	G	H	J	K	ØL	ØX	i	N _{max} RPM	S (DIN 6499)	T Nm	VERSION	P	SUITS FOR
SD6133	30	100	67	55	62	49.5	64.5	45.5	132	48	8	1-16	1:1	6000	ER25	40	R	W16X0.8X30°X18-9b	DRIVEN TOOL DISC VDI Ø30 BORE

DOUBLE END

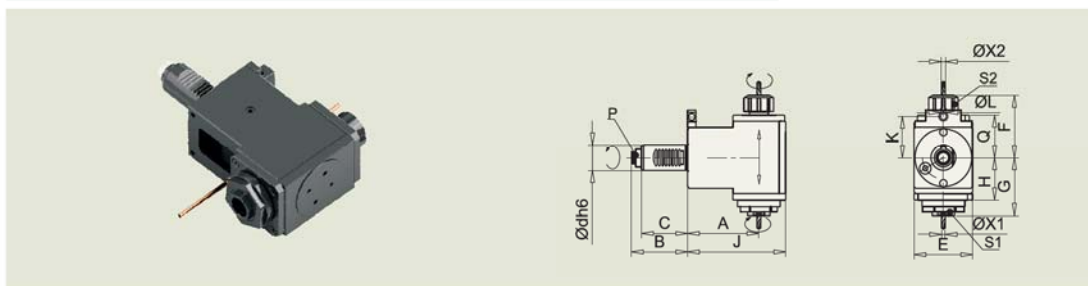

CODE	Ødh6	A	B	C	E	F	G	H	J	K	Q	ØL	ØX1	ØX2	S1 (DIN 6499)	S2 (DIN 6499)	i	N _{max} RPM	T Nm	P	SUITS FOR
SD6125	30	85	67	55	70	75.5	68.5	49.5	117	48	50	8	1-16	1-13	ER25	ER20	1:1	6000	40	W16X0.8X30°X18-9b	DRIVEN TOOL DISC VDI Ø30 BORE
SD6129	30	100	67	55	62	75.5	68.5	49.5	132	48	50	8	1-16	1-13	ER25	ER20	1:1	6000	40	W16X0.8X30°X18-9b	DRIVEN TOOL DISC VDI Ø30 BORE
SD6219	40	100	75	63	76	78.5	74.5	53	141	56	53	10	1-20	1-13	ER32	ER20	1:1	5000	70	W20X0.8X30°X24-9b	DRIVEN TOOL DISC VDI Ø40 BORE
SD6229	40	120	75	63	76	78.5	74.5	53	161	56	53	10	1-20	1-13	ER32	ER20	1:1	5000	70	W20X0.8X30°X24-9b	DRIVEN TOOL DISC VDI Ø40 BORE

AXIAL TOOL HEAD

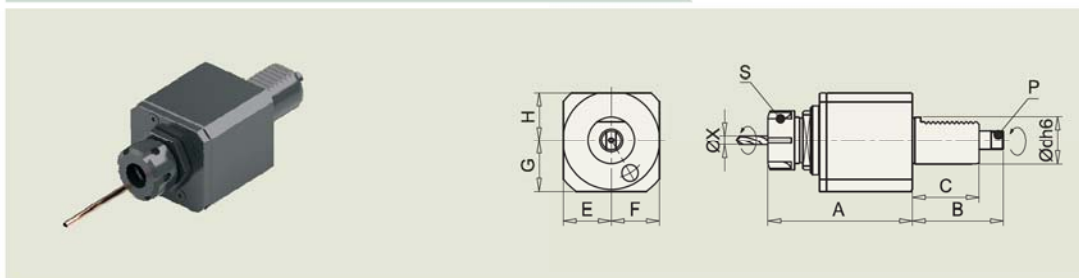

CODE	Ødh6	A	B	C	E	F	G	H	ØX	i	N _{max} RPM	S DIN 6499	T Nm	P	SUITS FOR
SD6144	30	94	62	50.5	30	30	30	28	1-13	1:1	6000	ER20	40	Ø12X6X7	DIPLOMATIC TURRET
SD6124	30	98.5	62	50.5	30	30	30	28	1-16	1:1	6000	ER25	40	Ø12X6X7	DIPLOMATIC TURRET
SD6137	30	98.5	66.5	55	30	30	30	28	1-16	1:1	6000	ER25	40	Ø13.5X8X7	EWS TURRET
SD6236	40	123	72	56	41	41	43	40	1-20	1:1	5000	ER32	70	Ø14X8X8	DIPLOMATIC TURRET

RADIAL TOOL HEAD

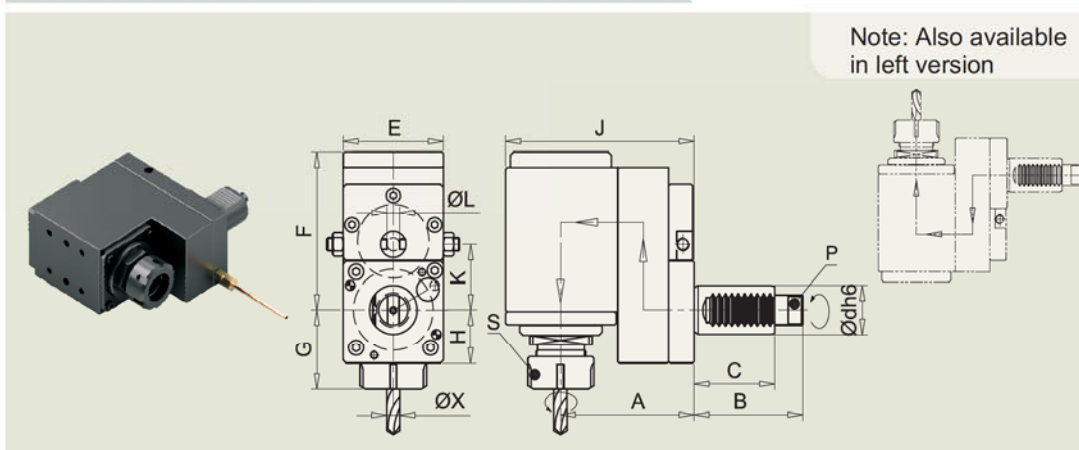

CODE	Ødh6	A	B	C	E	F	G	H	J	K	ØL	ØX	i	N _{max} RPM	S DIN 6499	T Nm	VERSION	P	SUITS FOR
SD6108	30	84	62	50.5	63	96.5	49	33	119	40	8	1-16	1:1	6000	ER25	40	R	Ø12X6X7	DIPLOMATIC TURRET
SD6141	30	84	66.5	55	63	96.5	49	33	119	40	8	1-16	1:1	6000	ER25	40	R	Ø13.5X8X7	EWS TURRET
SD6212	40	91	72	56	80	106.5	43	43	131	63	10	1-20	1:1	5000	ER32	70	R	Ø14X8X8	DIPLOMATIC TURRET

RADIAL TOOL HEAD - DIRECT

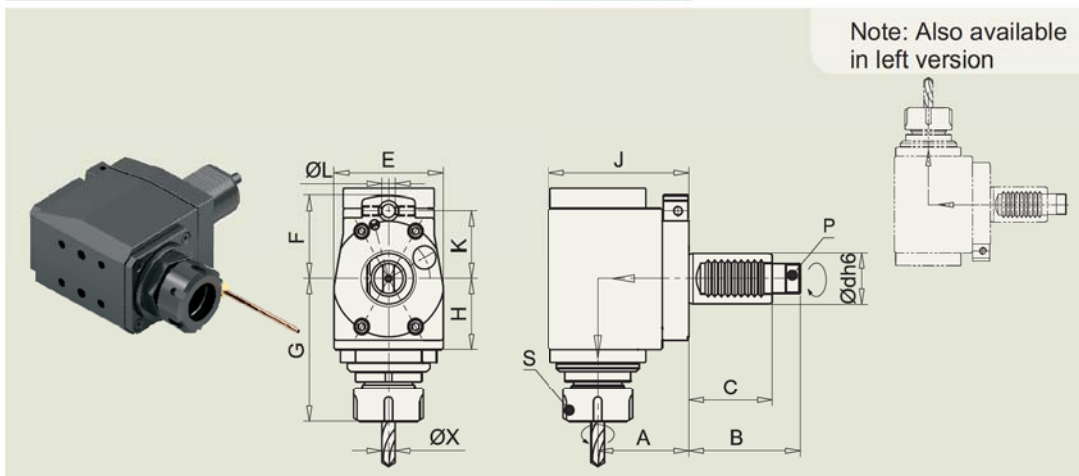

CODE	Ødh6	A	B	C	E	F	G	H	J	K	ØL	ØX	i	N _{max} RPM	S DIN 6499	T Nm	VERSION	P	SUITS FOR
SD6142	30	55	62	50.5	66	53	84.5	41.5	85	40	8	1-16	1:1	6000	ER25	40	R	Ø12X6X7	DIPLOMATIC TURRET

AXIAL TOOL HEAD

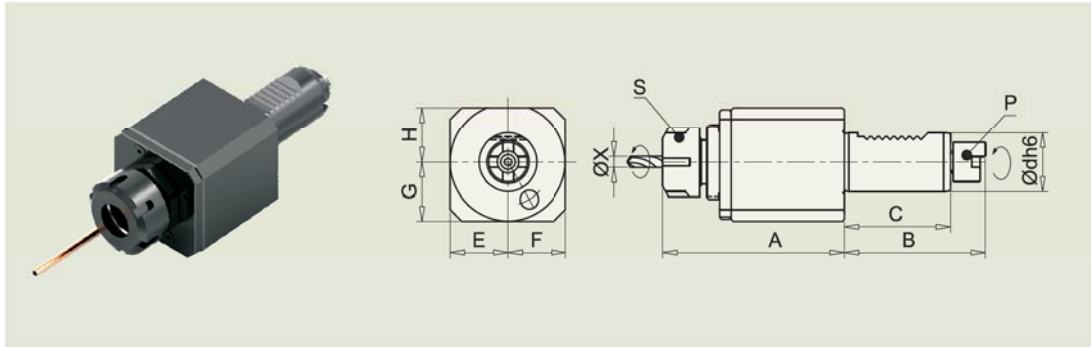

CODE	Ødh6	A	B	C	E	F	G	H	ØX	i	N _{max} RPM	S DIN 6499	T Nm	P	SUITS FOR
SD5903	16	65	48	35	21	25	21	21	1-7	1:1	6000	ER11	6.3	Ø14.5X4X4	BARUFFALDI TURRET
SD6143	30	98.5	59	45	30	30	30	28	1-16	1:1	6000	ER25	40	Ø24X6X3.2	BARUFFALDI TURRET

RADIAL TOOL HEAD - DIRECT

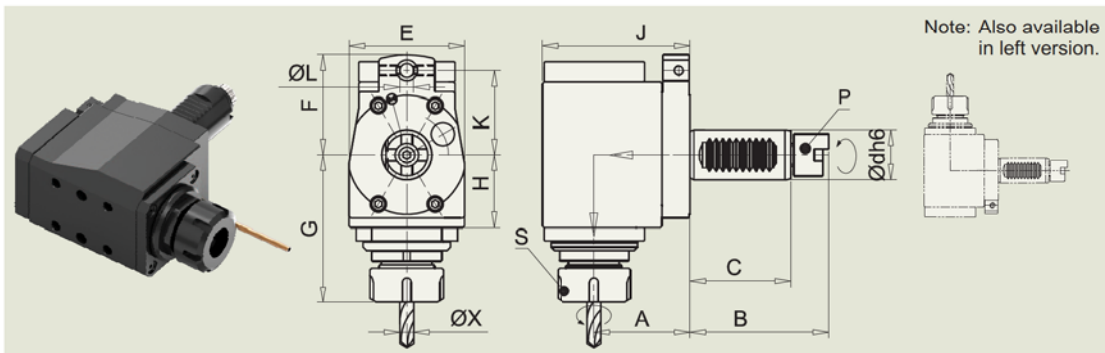

CODE	Ødh6	A	B	C	E	F	G	H	J	K	ØL	ØX	i	N _{max} RPM	S DIN 6499	T Nm	VERSION	P	SUITS FOR
SD5904	16	34	48	35	42	61	46	25	50	54	8	1-7	1:1	6000	ER11	6.3	R	Ø14.5X4X4	BARUFFALDI TURRET

CUSTOMISED DRIVEN TOOL HOLDER

Apart from DIN 5482, 5480, 1809 & TOEM coupling we can make

Driven Tool Holders for other types of drive end coupling

Customer needs to provide drive end coupling details.